



FROSTI® **NEW**
FROST-PROOF OUTDOOR TAPS

// Get reliable water supply for outside.
Frost-proof all year round and hygienically safe.

KEMPER
DRIVING PROGRESS

FROSTI® **NEW**

Advancements take sophisticated technology to a new level

Reliable with long service life

As a robust, long-lasting outside tap that's specially designed to be particularly frost-resistant and hygienically sound, the KEMPER FROSTI® is essential for any garden or outside area of a building. FROSTI® is equipped with an anti-vacuum tap and automatically drains itself after every shut-off procedure. Therefore, no residual water is left behind in the frost-prone area, avoiding water damage caused by the tap freezing. This complete drainage also prevents bacteria growth due to stagnant water, maintaining drinking water hygiene.

The challenge

Is it possible to equip an already sophisticated product with new, meaningful features? KEMPER sought to answer this question with the help of its experienced technicians, as it's a case of accounting for unfavourable installation situations, discerning end users, improper use and undesired third-party access.





THE RESULT

From the knowledge it has gained, Kemper has developed numerous features in response to problems that arise. This is the new FROSTI®:

New functions

New installation advantages

Proven gunmetal

The new advantages in function and assembly

// New handle with over-twist protection and an elegant, uniform design

KEMPER has both a handle and a lockable handle, equipped with an outstanding functioning element, that being the integrated over-twist protection which prevents damage to the tap caused by it being closed with excessive force.

Additionally, the two handle variants and the socket key operated head are characterised by a uniform, consistent design. The tap integrates into the façade in an aesthetically pleasing manner.



When closing the tap, the handle is rotated until the closing point is reached.



The anti-twist protection prevents the handle mechanism from over-rotating past the closing point. This protects the components from being damaged by excessive closing force.



// **Theft protection**

The breather cap and socket key operated head are no longer screwed in but instead latch into the discharge body, creating a theft-proof connection.

// **Two-piece rosette**

The two-piece rosette adapts to the angle of the inclined bore so that it's always flush with the wall, ensuring a neat fit. Thanks to this, the tap benefits from an increased holding effect. This prevents the façade from being damaged when screwing on the discharge body and stops the external wall insulation from being pressed down.

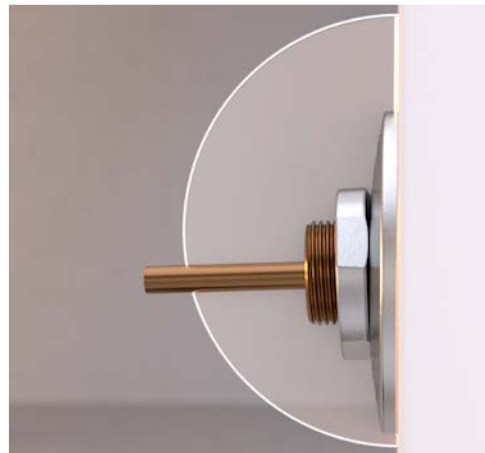
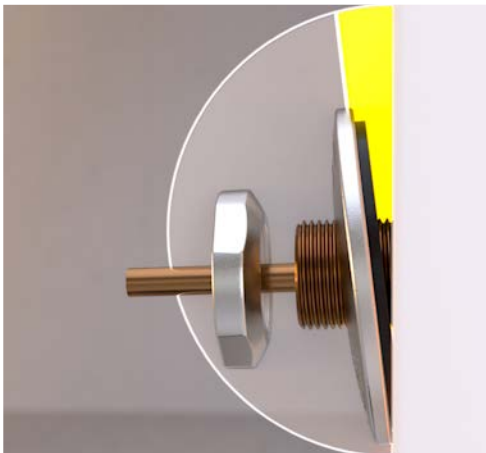



// **New mounting surfaces**

The newly designed mounting surfaces on the discharge body provide optimal support for technicians during installation and allow for installation without causing surface damage.



// **Optimised anti-twist protection**

The new anti-twist protection latches into the tap seat. The connection to the drinking water line is protected from radial and axial forces, even during shell assembly. Thanks to an integrated bore guide, holes no longer need to be marked.



// **Up to 45 l/min discharge rate**

End users benefit from the unmatched, new discharge rate of 45 l/min at 1 bar in DN 20 (40 l/min in DN 15).



// **Tried-and-tested gunmetal**

Clean, reliable, hard-wearing – the corrosion-resistant material gunmetal has proven itself in providing years of worry-free functional reliability in domestic water installations.

// **Spare parts availability**

Spare parts are available for all generations of the frost-proof FROSTI®, even if they're well past the minimum statutory period.



Also learn about the advantages in the new FROSTI® functions video!



YouTube



Product variants

There's a tap for every use case

KEMPER FROSTI® and FROSTI® XL

For installation in the shell construction phase

The kit allows the installation of the tap as early as the construction phase. The discharge body is mounted after the outer wall has been completed. Installation depths of up to 415 mm (XL variant up to 530 mm) can only be achieved with such an end-to-end length. Additionally, the extension allows the thermal insulation system to be bypassed.

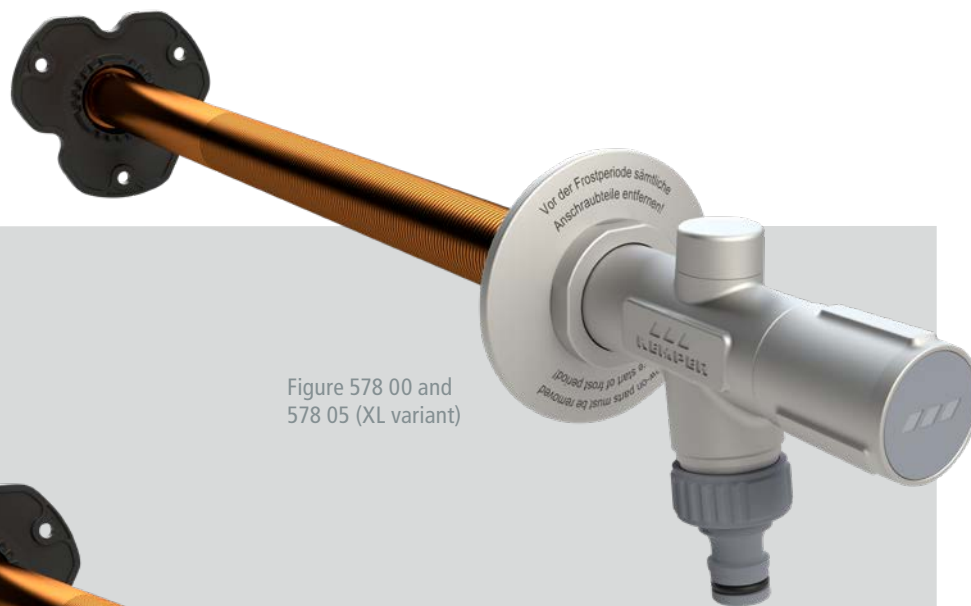

Figure 578 00 and
578 05 (XL variant)

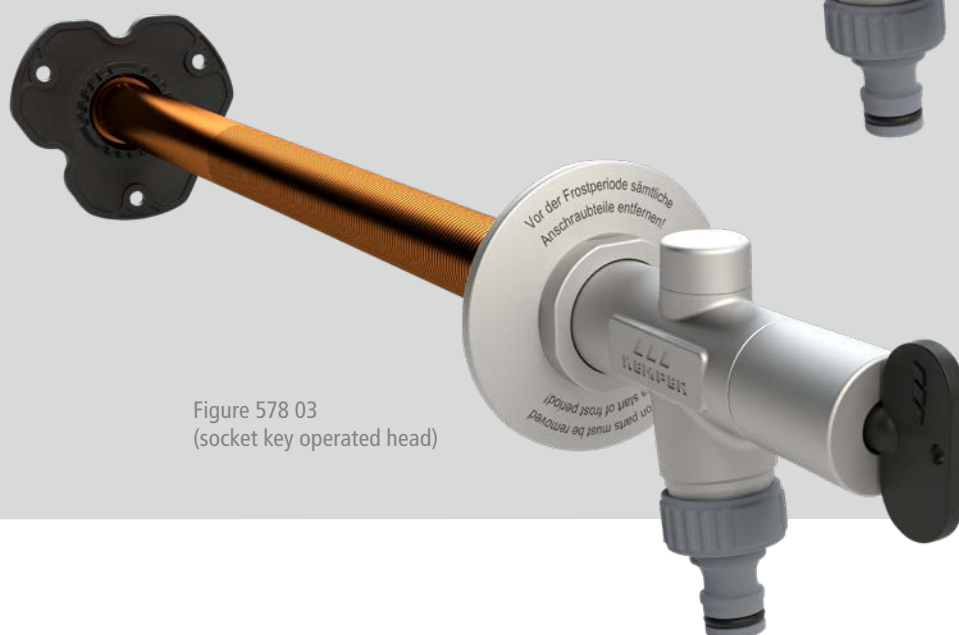

Figure 578 03
(socket key operated head)

FROSTI® pre-assembled design
For installation in finished façades

The tap comes pre-assembled with a total outer diameter of just 27 mm and a movable rosette, allowing for quick and simple installation in already constructed outer walls

- // For wall thicknesses from 150 mm, can be extended to any length on site
- // With universal R 1/2" connector, suitable for every installation system



Figure 579 02

INFO

Functions

- // With just two turns FROSTI® can be fully opened, reaching the maximum discharge rate.
- // The tap automatically drains itself fully after every shut-off procedure, preventing the tap from freezing and avoiding water damage.
- // The absence of stagnant residual water means no contamination will occur.

Overview of part numbers

| Part no. | Product description | Nominal width |
|--------------------------|--|----------------|
| 5780001500 5780002000 | FROSTI® frost-proof outdoor tap, with operating handle, construction set version | DN 15 DN 20 |
| 5780301500 5780302000 | FROSTI® frost-proof outdoor tap, with socket key, construction set version | DN 15 DN 20 |
| 5780501500 5780502000 | FROSTI® XL frost-proof outdoor tap, with operating handle, XL construction set version | DN 15 DN 20 |
| 5790201500 | FROSTI® frost-proof outdoor tap pre-assembled design | DN 15 |

Accessories

For optimal installation

FROSTI® fixing set

The FROSTI® fixing set (part no. 5780000500) ensures the tap is securely in place in the brickwork even when the mechanical load on the façade is higher, e.g. double-sheet outer wall. This prevents signs of wear on the plaster or façade.

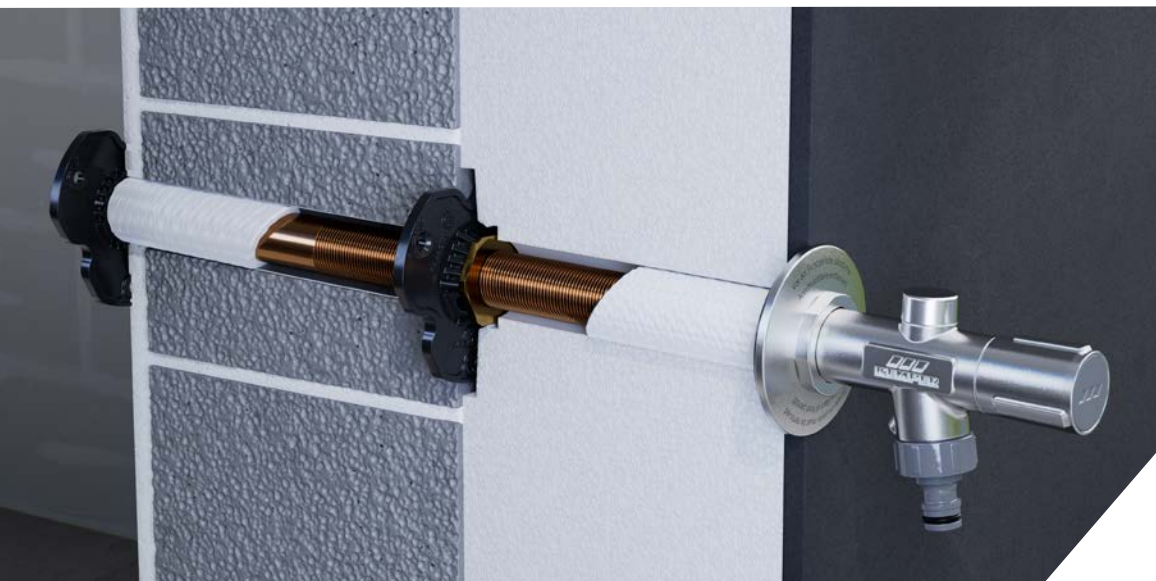



Lockable handle

Protection against impermissible removal of water by unauthorised third parties – and much more! The lockable cap (part no. 5780000300) is compatible with all FROSTI®s since 2009 and is an indispensable accessory for the FROSTI® NEW thanks to a range of new features!

The elegant, slim design fits in perfectly with the design language of the handles and ensures comfort when gripping. The integrated over-twist protection prevents damage to the tap caused by it being closed with excessive force. It can now be efficiently installed and removed in under a minute without the need for a separate removal key. Optional master key cylinder available when ordering.



FROSTI® extension

Thanks to the FROSTI® extension (part no. 5780000200), the frost-proof outdoor tap (Figure 578 00, 578 03 and 578 05) can be adapted with infinite variability between 30 to 250 mm to modified installation depths, e.g. over the course of cleaning a building with new external insulation.

Compatibility from old to new

Upgrading from old models (manufactured from 2009 onwards) with the new over-twist protection is straightforward and efficient, as the new handle and the lockable handle can be retrofitted at any point.

For models manufactured between 2006 and 2008, a complete retrofit set is available with a discharge body, rosettes and a new handle.

Environmental protection and sustainability

Our responsibility as a manufacturer

During the development of the new FROSTI®, making the production process as sustainably and resource-friendly as possible was top priority. For example, plastics were avoided wherever possible, placing greater emphasis on the use of recycled material.

You can find more information on sustainability at KEMPER at www.kemper-group.com



